

# Carretas Transportadoras de Grãos para Terreiro

Metallic Grain Carts for Drying Yard  
Carretas Transportadoras de Granos para Terrero



PA-CT/5



PA-CAR/250



**PALINI & ALVES LTDA.**

MÁQUINAS AGRÍCOLAS

Tecnologia sem limites • Technology without limits • Tecnología sin límites

# Carreta Transportadora de Grãos para Terreiro

## Metallic Grain Cart for Drying Yard | Carretas Transportadoras de Granos para Terrero

A carreta transportadora de grãos para terreiro Palini & Alves, foi construída especialmente para esparramar cafés em terreiros de qualquer dimensão.

- Tampas móveis removíveis;
- Regulagem de espessura da camada do café;
- Estrutura metálica;
- Fundo perfurado para escoamento de água;
- Estreita e robusta, específica para terreiros;
- As carretas para terreiro PA-CAR/250C e PA-CAR/250M são modelos para áreas menores, dotadas de pneus maciços ou câmaras com fundo perfurado para escoamento de água.

The Metallic Grain Cart for Drying Yard Palini & Alves was designed to spread coffee grains in drying yards of any sizes.

- Removable and movable lids;
- Coffee layer thickness regulation;
- Metallic structure;
- Perforated bottom for water outflow;
- Narrow and strong, special to coffee plantations;
- The PA-CAR/250C and PA-CAR/250M metallic grain carts are models designed for smaller areas, built with solid tires or tubes, and perforated bottom for water outflow.

La carreta transportadora de granos para terrero Palini & Alves ha sido construída especialmente para esparcir cafés en terreros con cualquier dimensión.

- Tapas móviles removibles;
- Reglaje del espesor de la capa de café;
- Estructura metálica;
- Fondo perforado para el flujo del agua;
- Estrecha y robusta, específica para terreros;
- Las mini carretas PA-CAR/250C y PA-CAR/250M son los modelos para las áreas más pequeñas, dotadas de neumáticos macizos o câmaras.

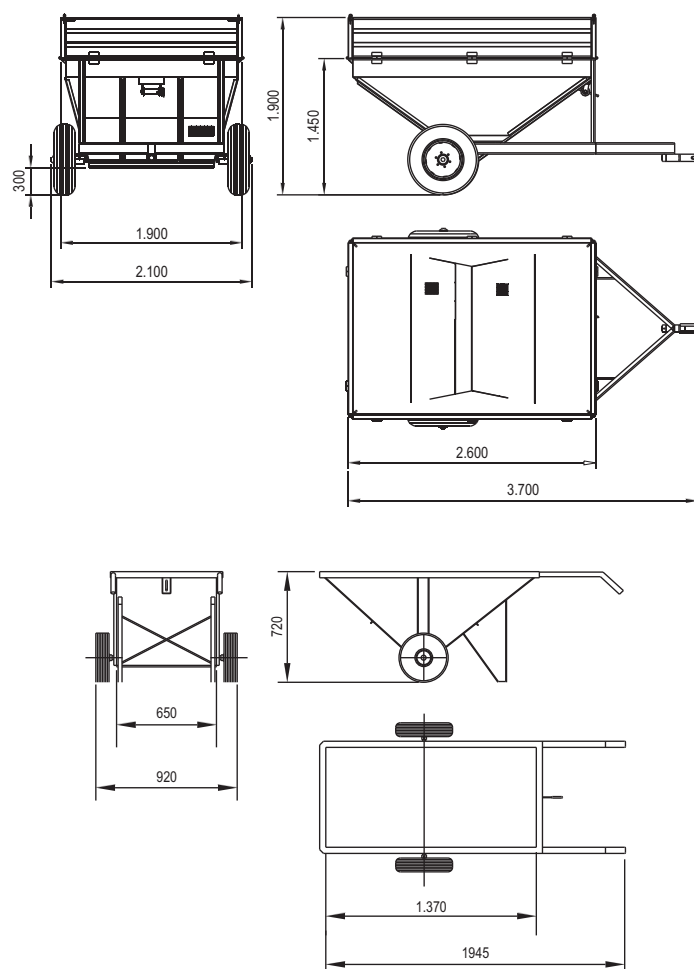

### Características Técnicas Technical Data | Características Técnicas

Modelo Model Modelo	Capacidade Capacity Capacidad	Peso Weight Peso
PA-CT/5	5.000 l / 5.000 Kg	524 Kg
PA-CAR/250M	250 l / 250 Kg	50 Kg
PA-CAR/250C	250 l / 250 Kg	50 Kg



Rodovia SP 342 | Km 199 | 255 | Distrito Industrial Irmãos Del Guerra  
CEP 13990-000 | Espírito Santo do Pinhal | SP | Brasil  
Tel. 55 19 3661.9600 | Fax 55 19 3661.9601

www.palini Alves.com.br



**PALINI & ALVES LTDA.**  
MÁQUINAS AGRÍCOLAS